



SIGNIFIKANT



SIGNIFIKANT Aftermarket Information Platform

KEY BENEFITS

- Double productivity;
- Decrease lead time by 30%;
- Improve safety and compliance;
- Accelerate information retrieval;
- Strengthen channel and customer relationship;
- Increase maintenance productivity and asset availability;
- Desktop and web based catalogue;
- Tracking of parts history;
- Product model, assembly and chassis number wise search engine;
- Parts number wise search engine;
- Separate administration and dealers.

“A BUSINESS ABSOLUTELY DEVOTED TO SERVICE WILL HAVE ONLY ONE WORRY ABOUT PROFITS. THEY WILL BE EMBARRASSINGLY LARGE.”

- HENRY FORD, FOUNDER OF FORD MOTOR COMPANY

The Signifikant Platform is a solution for increased aftermarket sales through enhancing aftermarket information delivery, increasing equipment uptime, streamlining maintenance processes and expanding the spare parts business. The Platform may be integrated with your PLM or ERP solution and adds functionality for the aftermarket. The Signifikant Information Platform is especially designed for companies just like yours.

The Signifikant Aftermarket Platform offers:

- Dynamic delivery service and support information;
- Hierarchical, visual and table of contents navigation;
- Attributes and model based filtering;
- Multiple search functions, including field and full-text;
- Illustrated parts catalogue integration via hyperlink;
- Publishing of information through internet, webserver, CD, DVD and pdf document;
- Incremental update mechanism for remote deployment such as intranet, hosted environment and standalones;
- Multilingual;
- Handling of multiple brands;
- Note book and bookmarks;
- Ordering system.

CONTACT SIGNIFIKANT? Sweden (HQ): info@signifikant.se +46 8 735 58 90 · India: info-in@signifikant.se +91 22 2597 5661

MORE INFORMATION? Please visit www.signifikant.se

With innovative features like contents uploading through multiple delivery channels together with e-commerce capabilities, the Signifikant Platform provides unprecedented benefits to OEMs, operators and service providers.

1 Click on product to drill down to assembly

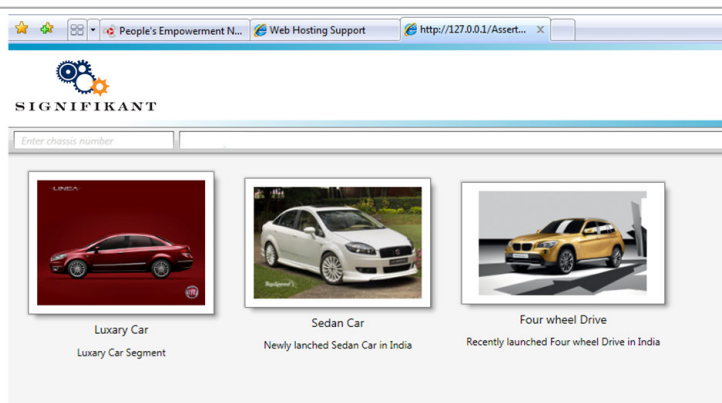

2 Graphical representation of part assembly mapped to product

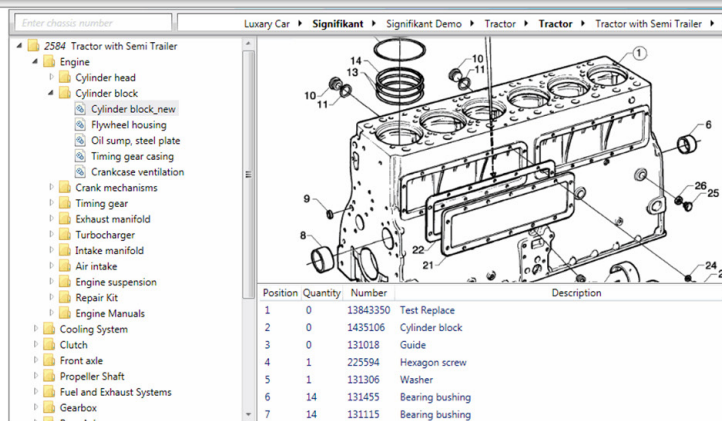

3 Select part and place order directly with ease

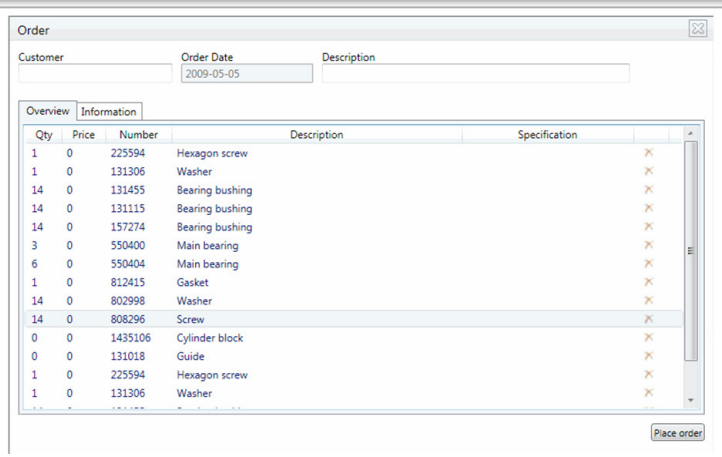



SIGNIFIKANT



Increase your aftermarket sales by 20%!

With your strategic work to increase aftermarket sales our solution will provide you the means to increase your aftermarket sales with 20% or more. Compete efficiently with third part vendors, increase your service staff's sales and generate higher margins. The Signifikant Platform will boost your total profit!

Margins are created in the aftermarket

Numerous surveys have been conducted within the aftermarket of manufacturing industry, all showing a clear shift towards the aftermarket as a driver for margins. As low-cost competition increase and product margins are put at peril, the trend escalates.

Still, despite the clear threat of low-cost competition, most manufacturing businesses choose to grow their aftermarket at the same rate as the over-all business. Simply, the aftermarket is not made a strategic tool to increase profitability - a possible business risk.

Growing the after market

For many businesses, the aftermarket is an untapped potential for growth. But strategic decisions are needed to exploit this potential.

Research suggests that a strategy to increase the aftermarket will include operational investments in aligning service and sales processes as well as supporting IT-solutions for these processes.

Short and long term effects may be reached through focusing on sales of parts and optimizing the delivery of exactly the right parts to existing customers.

Increase your aftermarket sales

A key issue in increasing sales of parts is aligning sales and service processes. Service staff is your front end to the customer, and they are the key to achieving both customer satisfaction and increased parts sales.

But do they have the right tools to sell? Turn your service staff into a highly efficient sales department.

Increase customer satisfaction

The quality of the support given to a customer is greatly dependent upon a prompt handling of down-time. Top 90% of manufacturing businesses deliver the right part to the customer 99.7% of the time.

The long term effect is increased customer satisfaction, higher part sales and increased profit.

Turn your aftermarket into a profit machine

With strategic work and operational improvement with proper IT-support, you may achieve 20% or higher increase in aftermarket sales!

How much does that boost your total profit?





The Signifikant Platform is designed for usability, flexibility, reliability and total ownership.

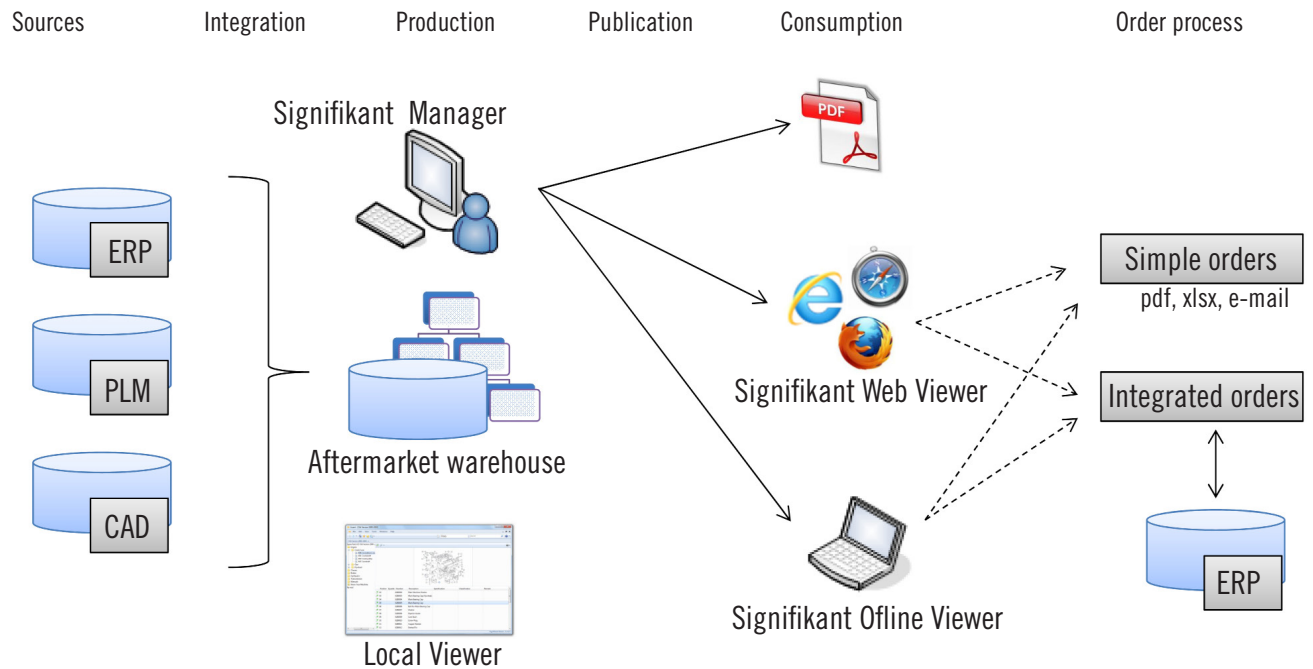

Technologies and Platforms

The core of the platform is an information server that is a platform both for services and data warehouse.

- Microsoft Windows Server operating system
- IIS web server
- Microsoft .Net application framework
- Microsoft SQL server
- Xml data integration and SOAP communication protocol



ABOUT SIGNIFIKANT

Signifikant is an IT-provider focused on delivering state-of-the art software solutions and services for the aftermarket. Signifikant's vision with the Signifikant Platform suite is to Make Your Aftermarket into a Profit Machine.

- Usability and design. The most easy to use and well designed web viewer, with powerful and fast search functionality.
- Very strong process support. Good process support is the foundation of information quality. The right part to the right machine.